

Hydraulic Microdrilling Rig

SM-4

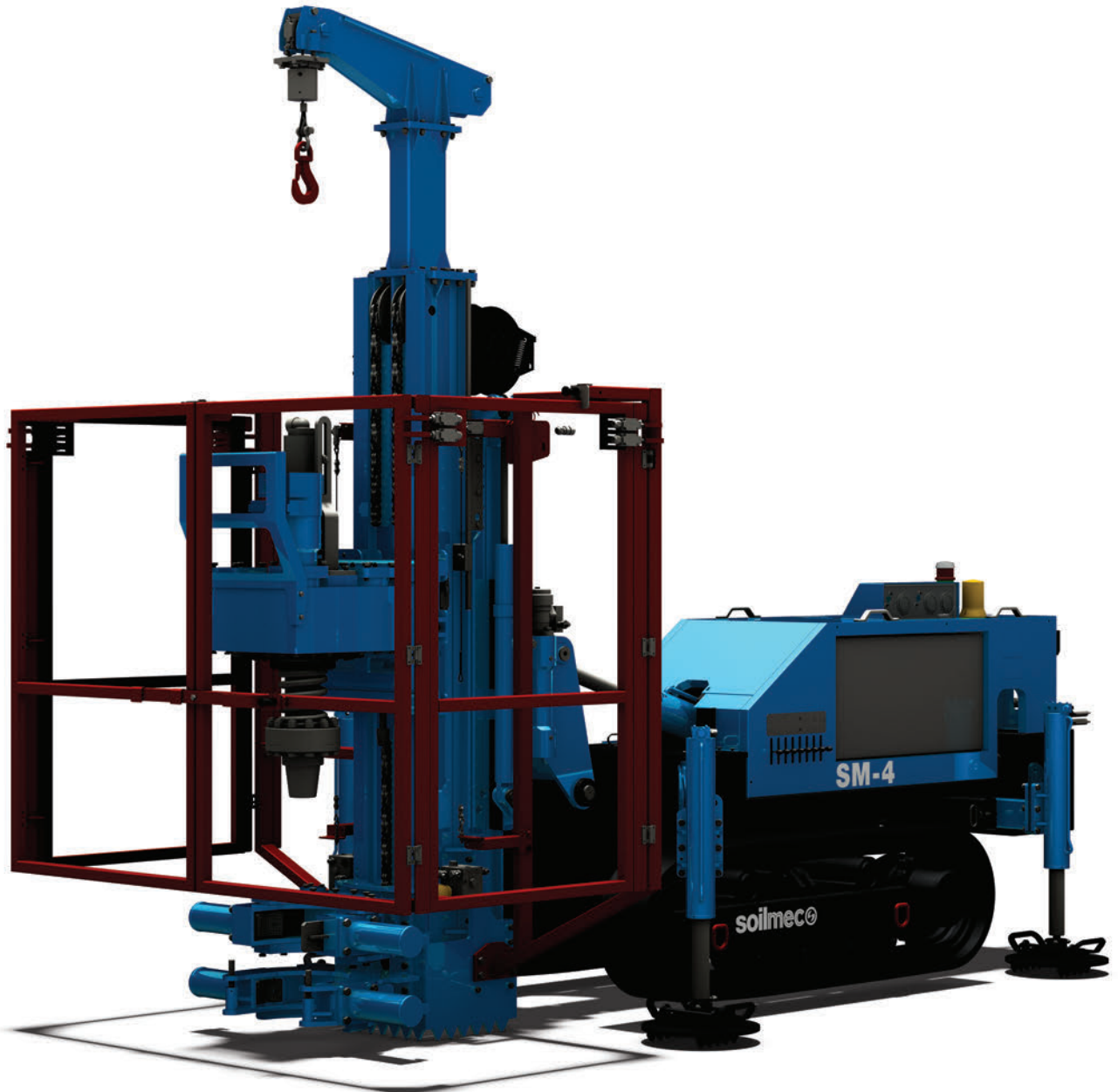

soilmec 
Drilling and Foundation Equipment

SM-4 Microdrilling Rig

APPLICATIONS

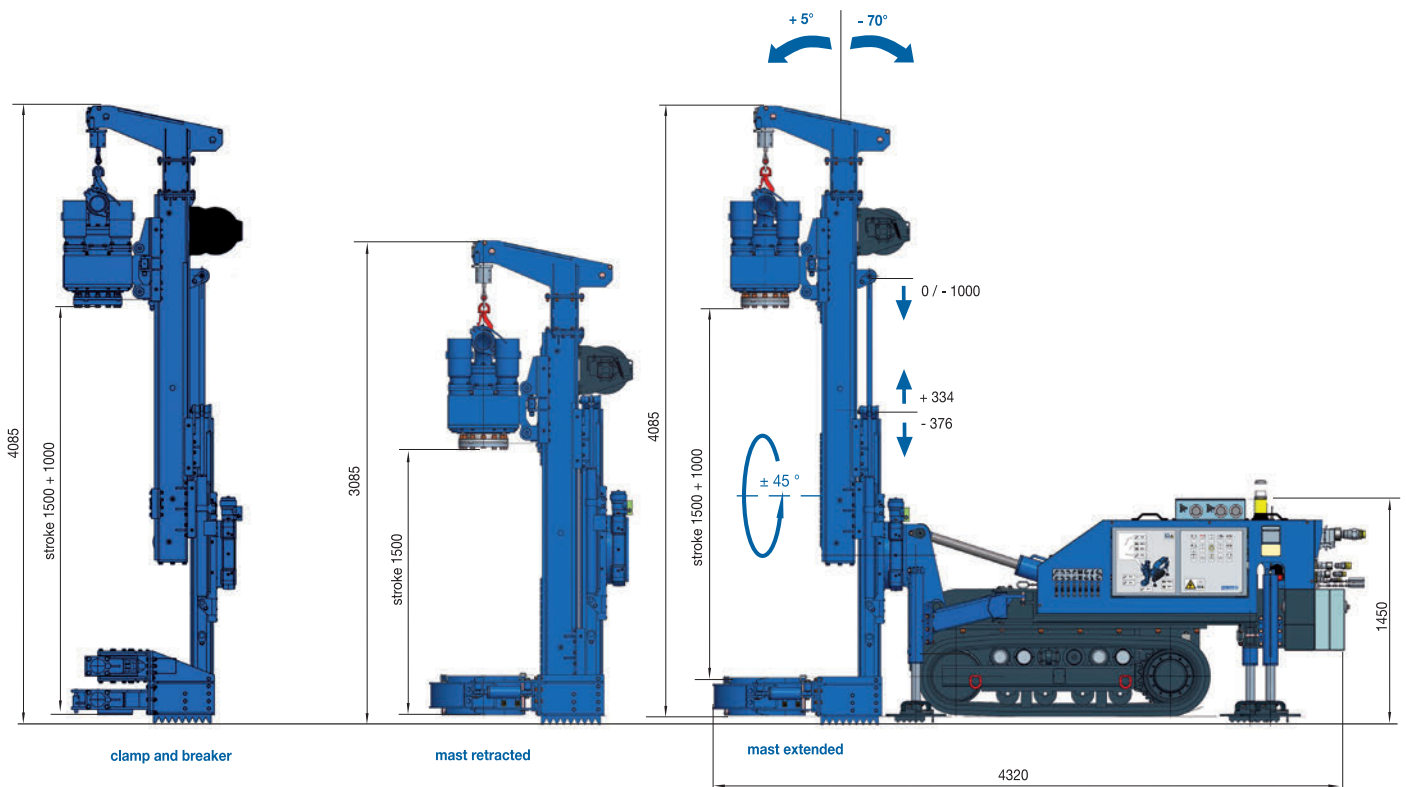

Hoist & Feed system

Feed type	Cylinder	Cylinder
Feed stroke	1500 + 1000 mm	59.1 + 39.4 in
Maximum hoist pull/feed force	70 / 46 kN	15736 / 10341 lbf
Maximum speed (fast/low operation)	21 / 7 m/min	69 / 23 ft/min

Rotary head	HT3400V	HT3400V
Gear box type	3 ratios	3 ratios
Maximum torque	3350 daNm	24708 lbf*ft
Maximum drilling speed	58 rpm	58 rpm
Inner passage	134 mm	5.3 in

SM-4 Microdrilling Rig

TECHNICAL DATA SHEET

Operating weight separated power pack (approx.)		
	3700 kg	8157 lb
Undercarriage		
	Fixed gauge	Fixed gauge
- Track shoe width	250 mm	9.8 in
- Overall length	1971 mm	77.6 in
- Overall width	1180 mm	46.5 in
Diesel Engine		
- Make and model	DEUTZ - TCD 4.1 L04 4V Tier 4i	DEUTZ - TCD 4.1 L04 4V Tier 4i
- Power rating	115 kW @ 2000 rpm	154 HP @ 2000 rpm
- Sound power level and sound pressure level	LwA 104 - LpA 85 dB(A)	LwA 104 - LpA 85 dB(A)
- Fuel tank capacity	200 l	44 US gal

Operating weight base machine (approx.)		
	6100 kg	13448 lb
Undercarriage		
	Variable gauge	Variable gauge
- Track shoe width	220 mm	8.7 in
- Overall length	1952 mm	76.9 in
- Overall width (ext/retr)	1200 / 740 mm	47.2 / 29.1 in
- Travelling speed	3,33 km/h	2.07 mph
- Ground stabilizers	n° 2 rotatable on front + n° 2 extendable on rear	n° 2 rotatable on front + n° 2 extendable on rear
Hydraulic system		
- Main pumps: variable axial pumps	200 l/min	53 US gal/min
- Set pressure main pumps	30 MPa	4351 psi
- Auxiliary pumps: gear pumps	86 + 32 l/min	22.7 + 8.5 US gal/min
- Hydraulic oil tank capacity	403 l	106 US gal
Clamp & Breaker		
- Nominal size	50 - 320 mm *	2.0 - 12.6 in *
- Maximum clamping force	141 kN	31698 lbf
- Maximum breaking torque	4000 daNm	29502 lbf*ft
Guide for CFA		
- Max diameter auger	600 mm	23.62 in
- Max diameter casing	610 mm	24 in
Service winch		
- 1st layer line pull (nominal/effective)	20 kN	4496 lbf
- 1st layer nominal rope speed	43 m/min	141 ft/min
- Rope diameter	8 mm	0.31 in

* up to 510 mm

STANDARD EQUIPMENT

- | | | |
|--|---|---|
| <ul style="list-style-type: none"> • Extendable undercarriage • Telescopic drill mast • Prearrangement for mud pump | <ul style="list-style-type: none"> • Pneumatic inline DTH lubricator • Cable remote for tramming • Load Sensing hydraulic system | <ul style="list-style-type: none"> • Full radio remote control for all operation • Hydraulic control for kinematism |
|--|---|---|

OPTIONAL EQUIPMENT

- | | | |
|--|--|--|
| <ul style="list-style-type: none"> • Separated Electric power pack (110 kW) • Wide range of rotary heads • Power pack on crawler track or on skid | <ul style="list-style-type: none"> • Triplex pump for Foam • CFA kit • Top hammer kit | <ul style="list-style-type: none"> • Jet grouting kit • Integrated foam pump |
|--|--|--|

SM-4 Microdrilling Rig

TRANSPORT, DIMENSIONS AND WEIGHTS

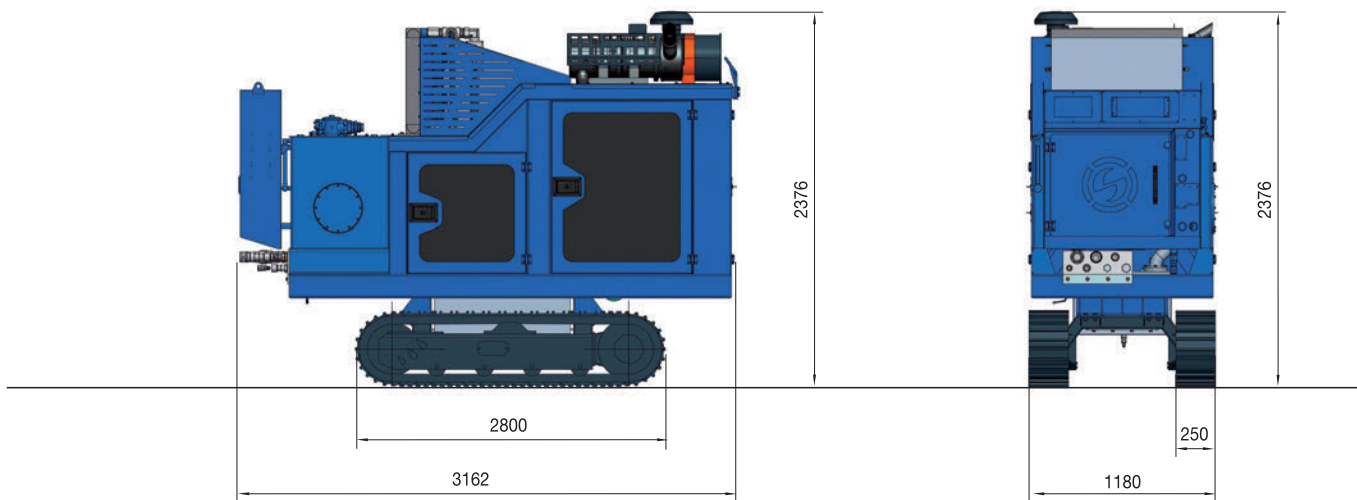

Power pack

Length	3162 mm	124.5 in
Width	1180 mm	44.45 in
Height	2376 mm	93.54 in
Weight	3700 kg	8157 lb

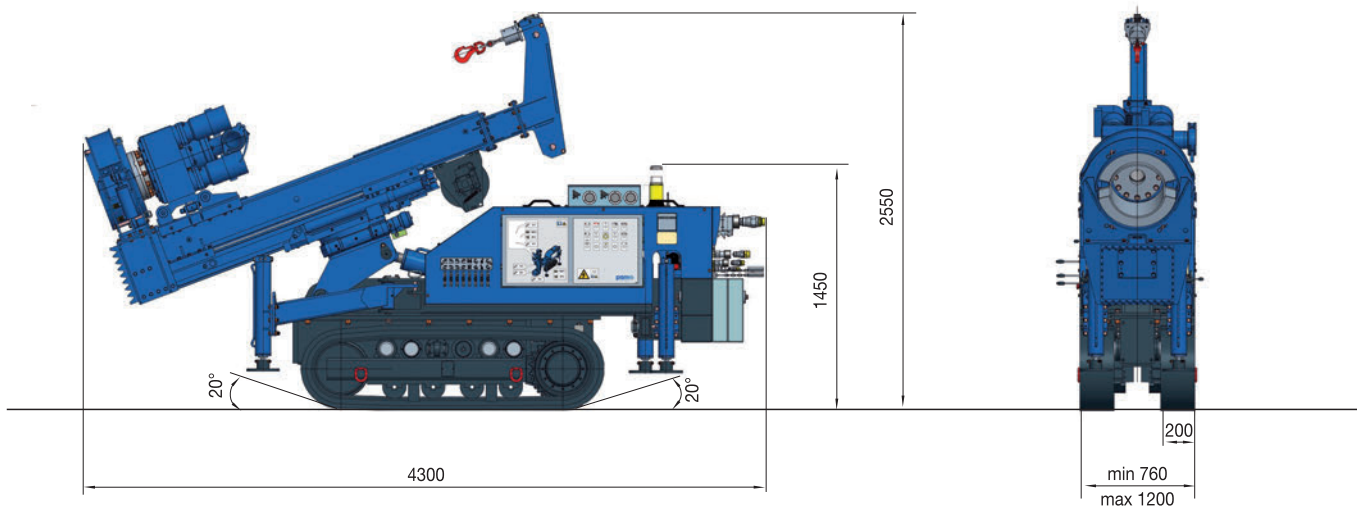

Base machine

Length	4300 mm	100.4 in
Width	760 mm	29.9 in
Height	2550 mm	78.7 in
Weight	6100 kg	13448 lb

This brochure has been edited and distributed by SOILMEC Spa. The present document cancels and override any previous ones. This brochure shall not be distributed, reproduced or exhibited without SOILMEC Spa. authorization in accordance with to SOILMEC web site disclaimer condition.

SOILMEC Spa distributes machinery and structures all over the world, supported by SOILMEC Spa subsidiary companies and dealers. The complete Soilmec network list is available on the web site www.soilmec.it