

SR-35 EVOLUTION



soilmec 
Drilling and Foundation Equipment

SR-35 EVO. Giant steps are what you take...

The-30-ton-class piling rigs are the ones that more than any others stand for Soilmecc.

Since 1995, when the first R-312 was produced, these compact, agile and yet powerful rigs have become the standard of reference in the field of ground engineering.

From Northwest Territories to Ghana, From Mexico City to Pisa leaning tower, these rigs have been virtually working in all latitudes tackling a variety of soils, rocks and weather conditions.

After more than 1500 units sold,
Soilmec is introducing a new step in the segment.

R-312 R-312 SR-35 SR-35



-312
2HD
312/200
-30
R-30 EVO

1500 units
sold in the last 25 years



Soilmec best selling rigs ever

From truck to pile in a blink.

The SR-35 EVO is a very fast machine, easy to operate, the best answer to those specialists who are looking for performance and agility on job sites. The rig maintains the distinctive design features that have made the fortune of the SR-30. The compact geometry of the base machine and the parallelogram system allows to rapidly shifting from transport to working configuration, keeping a large working radius and the possibility to drill large diameter piles.

The machine can be moved with the kelly bar still mounted on, hence drastically reducing the setup time.



Less than 30 minutes
from truck to pile.



Evolution on the outside. Revolution on the inside.

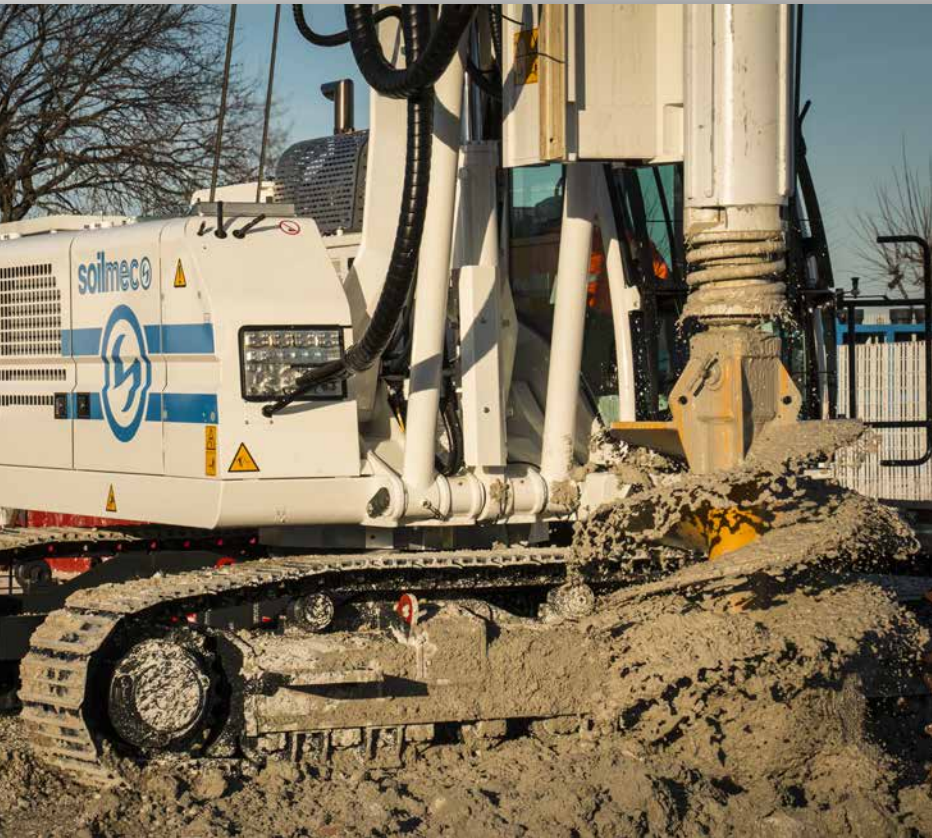

The SR-35 is installed with the latest generation Stage-V Diesel engines set up with the low idle control able to improve efficiency and mitigate noise pollution.

The selected engine is the Cummins B6.7.

It is an extremely powerful engine, it is efficient and flexible and finally helping the operator to easily deal with the most demanding jobs.

Compared to the SR-30, this **new engine allows 5% lower specific fuel consumption even by delivering up to 12% more power.**

The hydraulic and electric systems design follows the path which had already been drawn for the SR-30 and therefore Nos. of components are reduced in order to minimize energy losses, to ease maintenance and finally improving reliability.

The all new rotary-head features a **15% increased torque output through DMS regulation and a very high transmission efficiency.**

The electronic control of the hydraulic motor displacement brings advantages in terms of efficiency and effectiveness. When working in very hard rock the system provides all the torque available while adjust it at the minimum torque needed in case of easy soil.

Most important remain the fact that, during the drilling phase, the maximum possible speed is always used maximizing therefore the performance and the production rate.



Contemporary Piling Rig



The SR-35 EVO is a modern machine equipped with several accessories and devices designed to guarantee the highest level of connectivity, accessibility and safety.

The **DMS 4.0 system**, based on the IOT technology, enables to use the most advanced automatic functions lately developed by Soilmec:

Autodrilling, Autorotary, mast assisted lifting (*Soilmec patent*), automatic return to the hole center just to name some of the features which helps the operator work and increase his comfort during the working phases. The 12" DMS touch screen monitor is installed in the cab upper-right side corner leaving the operator with a perfect visibility on the drilling area.

The comfort and safety of the operator is one of the SR-35 main targets.

The features included are: cab's sliding door, air conditioning with control display, Radio and CD kit, FOPS protection, cab and excavation front light kit, bluetooth radio control for truck loading/unloading and operator side catwalk with handrails.



Soilmec & Comfort & Safety

Large Diameter Piles

Cylinder Crowd System

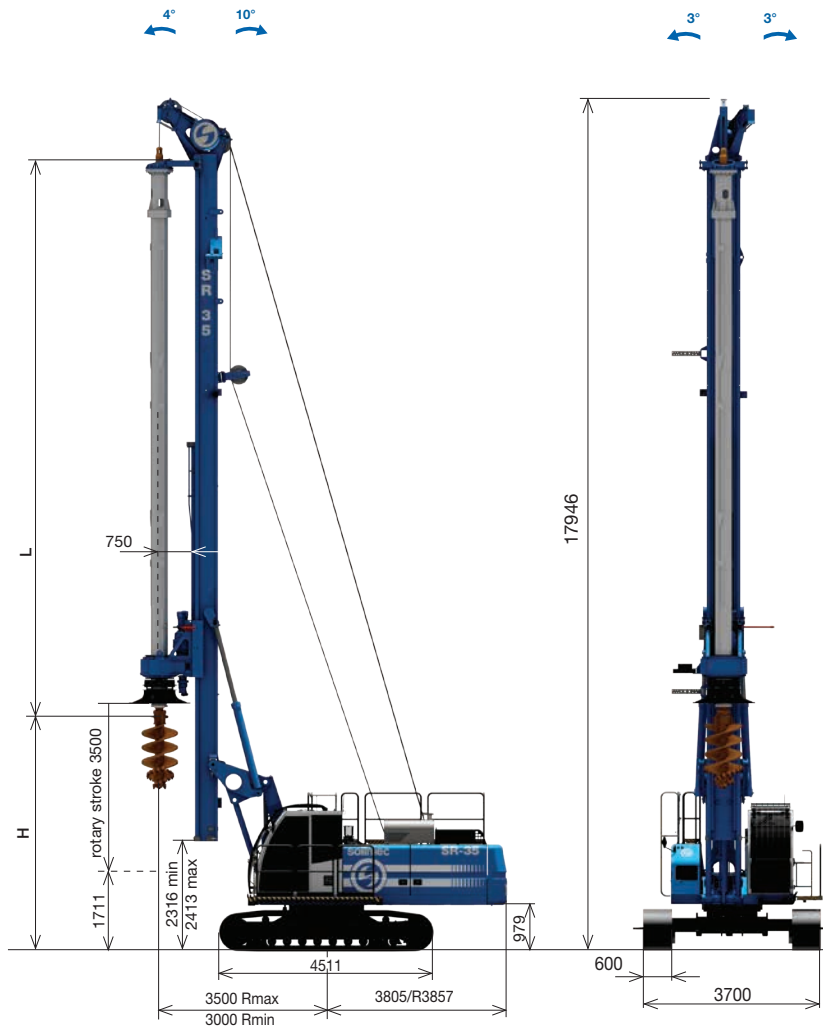

Extended Rathole version

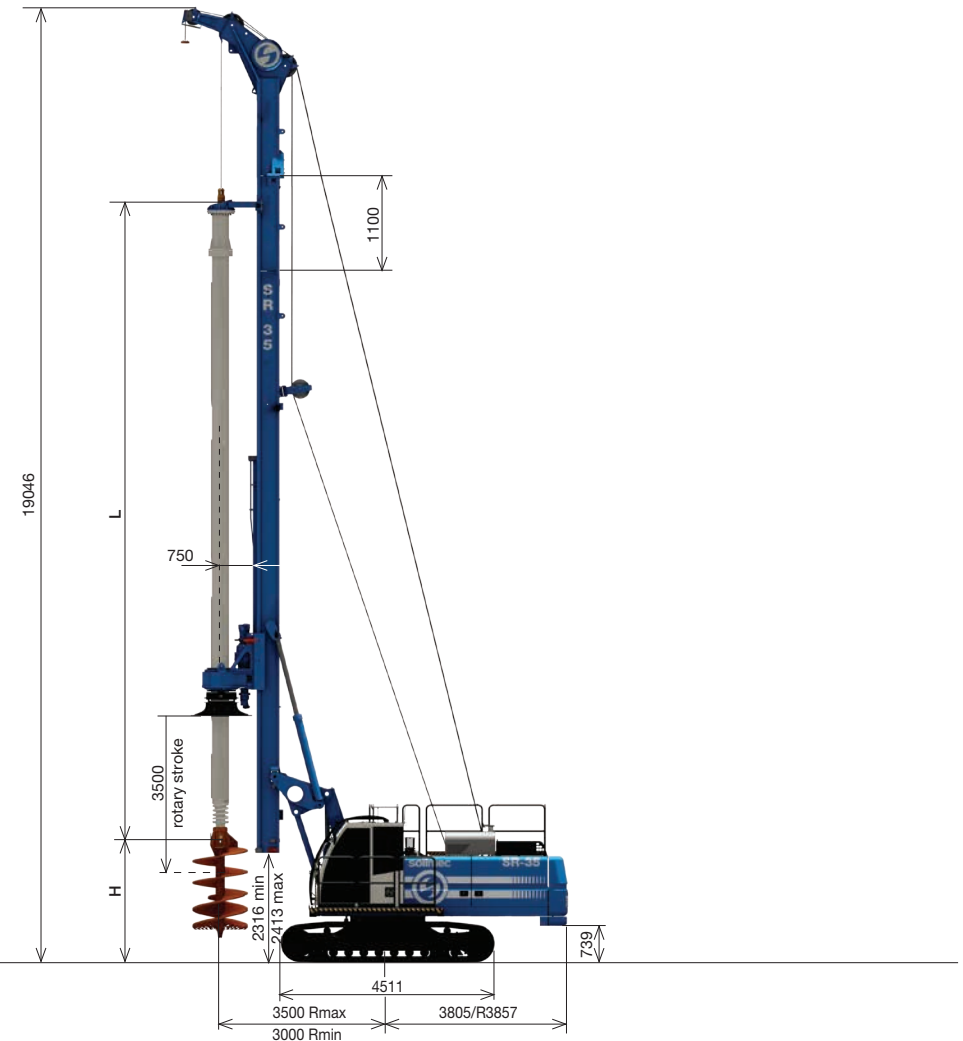

LDP - Large Diameter Piles - CCS version

Operating weight w/o kelly bar ¹	32700 kg	72090 lb
Max pile diameter (tool in front of the mast)	1500 mm	59.06 in
Max pile diameter (tool below mast) ²	3000 mm	118.11 in
Working radius	3000 - 3500 mm	118 - 137.8 in
Tail swing radius	3857 mm	151.85 in
Max pile depth-friction kelly	56,7 m	186.02 ft
Max pile depth-locking kelly	45,4 m	148.95 ft
Max pile depth (c/w rathole kit) - friction kelly ³	63,4 m	208.01 ft
Max pile depth (c/w rathole kit) - locking kelly ³	50,9 m	166.99 ft

¹ with segmental mast option the weight is 500 kg (1102 lb) more c/w Tier3 engine 300 kg (661 lb) less

² only for auger tool

³ 1,1 m (3.6 ft) mast extension & 1500 kg (3307 lb) additional counterweight

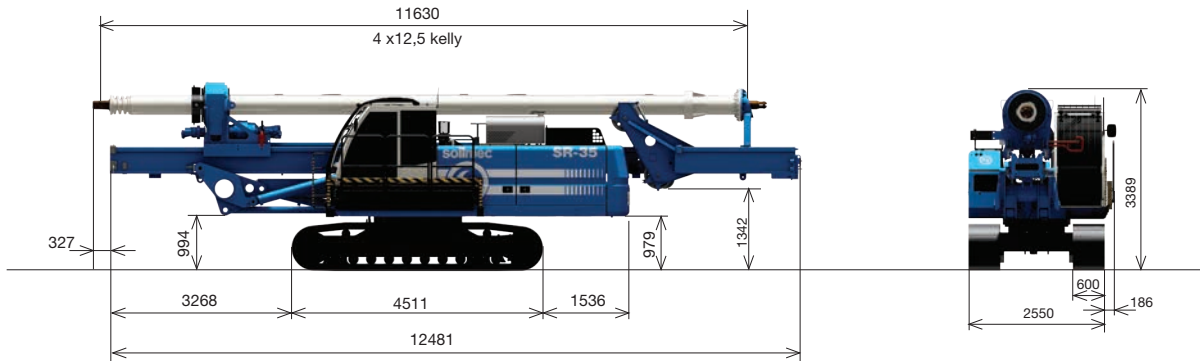

Transport in LDP - CCS version

	Standard		Extended Rathole	
Transport weight c/w kelly bar 4x9 *	36100 kg	79587 lb	-	-
Transport weight c/w kelly bar 4x12,5 *	37200 kg	82012 lb	-	-
Transport weight c/w kelly bar 4x13	-	-	40100 kg	88405 lb
Transport weight w/o kelly bar *	32700 kg	72091 lb	34600 kg	72421 lb
Transport length c/w kelly bar 4x12,5 *	14733 mm	48.3 ft	14013 mm	46.0 ft
Transport length c/w kelly bar 4x13	-	-	14513 mm	47.6 ft
Min transport length (mast dimension)	12481 mm	40.9 ft	13576 mm	44.5 ft
Transport width	2500 / 2736 mm	8.4 / 9.0 ft	2500 / 2736 mm	8.4 / 9.0 ft

*with segmental mast option the weight is 500 kg (1102 lb) more

Kelly bars for LDP

	Kelly type	Kelly dims.	Drilling Depth		Weight		L Length		H CCS SYSTEM	
			m	ft	ton	t (US)	m	ft	m	ft
3 parts	BL HD	3 x 7,5	19,4	63.6	2,9	3.2	8,5	27.9	5,0	16.4
	BL HD	3 x 9	24,2	79.4	3,4	3.7	10,2	33.5	5,0	16.4
	BL HD	3 x 11	29,4	96.5	4,0	4.4	11,8	38.7	4,3	14.1
	BL HD	3 x 12,5	33,8	110.9	4,4	4.9	13,3	43.6	2,8	9.2
	BL HD	4 x 7,5	25,6	84.0	2,9	3.2	8,4	27.6	5,0	16.4
4 parts	BL HD	4 x 9	32,3	106.0	3,4	3.7	10,0	32.8	5,0	16.4
	BL HD	4 x 11	38,7	127.0	4,0	4.4	11,6	38.1	4,5	14.8
	BL HD	4 x 12,5	45,4	149.0	4,5	4.9	13,3	43.6	2,8	9.2
	FR HD	4 x 7,5	25,9	85.0	2,9	3.2	8,4	27.6	5,0	16.4
	FR HD	4 x 9	32,4	106.3	3,4	3.7	10,0	32.8	5,0	16.4
	FR HD	4 x 11	38,9	127.6	4,0	4.4	11,6	38.1	4,5	14.8
	FR HD	4 x 12	43,9	144.0	4,3	4.8	12,9	42.3	3,2	10.5
	FR HD	4 x 12,5	45,5	149.3	4,5	4.9	13,3	43.6	2,8	9.2
	FR HD	5 x 9	40,1	131.6	4,1	4.5	10,0	32.8	5,0	16.4
	FR HD	5 x 10	45,4	149.0	4,4	4.9	11,0	36.1	5,0	16.4
5 parts	FR HD	5 x 11	48,5	159.1	4,8	5.3	11,6	38.1	4,5	14.8
	FR HD	5 x 12	54,8	179.8	5,2	5.7	12,9	42.3	3,2	10.5
	FR HD	5 x 12,5	56,8	186.4	5,4	5.9	13,3	43.6	2,8	9.2

5x kelly bar torque derate required

Extension Rathole version

Drilling depths

Kelly type	Kelly dims.	Drilling Depth		Weight		L Length		H CCS SYSTEM	
		m	ft	ton	t (US)	m	ft	m	ft
FR HD	4 x 13	48,2	158.1	4,6	5.1	14,0	45.9	3,2	10.5
FR/BL HD	4 x 13,5	51,0	167.3	4,8	5.3	14,8	48.5	2,6	8.5
FR HD	5 x 13	60,2	197.5	5,5	6.1	14,0	45.9	3,2	10.5
FR HD	5 x 13,5	63,4	208.0	5,7	6.3	14,6	47.9	2,5	8.2

5x kelly bar torque derate required

LHR

Low Head Room

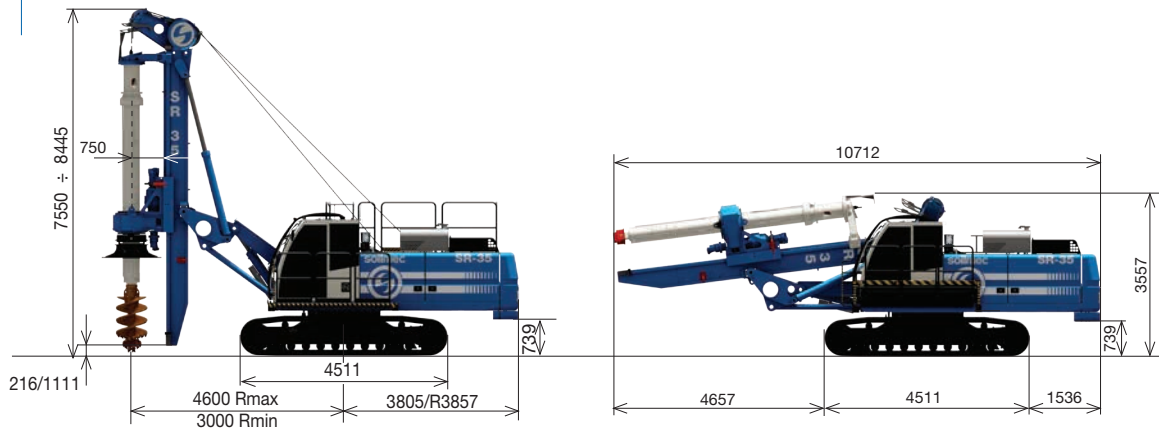

LDP - Large Diameter Piles - LHR version

Operating weight w/o kelly bar	32300 kg	71209 lb
Max pile diameter (tool in front of the mast)	1500 mm	59.06 in
Max pile diameter (tool below mast) ¹	3000 mm	118.11 in
Working radius	4600 - 3000 mm	181.10 - 118.11 in
Tail swing radius	3857 mm	151.85 in
Max pile depth-friction kelly (c/w 1,3 m - 4.3 ft mast extension)	16,8 (23,3) m	55.1 (76.4) ft
Max pile depth-locking kelly (c/w 1,3 m - 4.3 ft mast extension)	13,8 (19,1) m	45.3 (62.7) ft
Min operating height (c/w 1,3 m - 4.3 ft mast extension)	7,5 (8,8) m	24.6 (28.9) ft
Stroke	2550 mm	100.39 in
Pull up/down crowd force	123,7 / 101,8 kN	27808 / 22885 lbf
Main winch line pull (1 st layer)	100 kN	22481 lbf

¹ w/o foot mast

Transport in LDP - LHR version	Standard		Extended	
Transport weight c/w kelly bar 4x4 ¹	34200 kg	75398 lb	34950 kg*	77051 lb*
Transport weight c/w kelly bar 5x4 ¹	35500 kg	78264 lb	35450 kg**	78154 lb**
Transport length	10712 mm	35.1 ft	10651 mm	34.9 ft
Transport height	3557 mm	140 ft	3449 mm	135.8 ft
Transport width	2550/2736 mm	8.4/9.0 ft	2550/2736 mm	8.4/9.0 ft

*c/w kelly bar 4x5,5 **c/w kelly bar 5x5,5

¹ w/o cardan joint and casing flange

Drawing are not to scale All technical data are purely indicative and subject to change without notice

Kelly bars for LHR

Kelly type	Kelly dimens.	Drilling Depth *		Weight		L Length		H CCS SYSTEM	
		m	ft	ton	t (US)	m	ft	m	ft
BL HD	4 x 4	13,8	45.3	1,9	2.0	4,5	14.9	1,6	5.2
BL HD	4 x 5,5*	19,1	62.7	2,3	2.6	5,8	19.1	1,6	5.2
FR HD	5 x 4	16,8	55.1	2,2	2.5	4,5	14.9	1,6	5.2
FR HD	5 x 5,5*	23,3	76.4	2,8	3.1	5,8	19.1	1,6	5.2

5x kelly bar torque derate required

* c/w 1,3 m mast extension

Drilling depth with tool 1500 mm (4.9 ft) long

Always one step ahead

The high strength steel **segmental mast** engineered for this unit is composed by two elements linked by a flange. Such a design allows to shorten or to extend the mast according to the job site needs without removing the section linked to parallelogram system. The solution enables to rapidly convert the rig machine in to the LHR configuration.

7,5 m (24.6 ft) minimum operating height, multifunctionally and adaptability are therefore the main features.

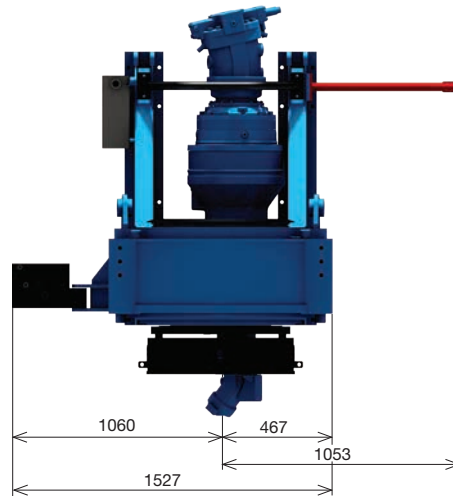
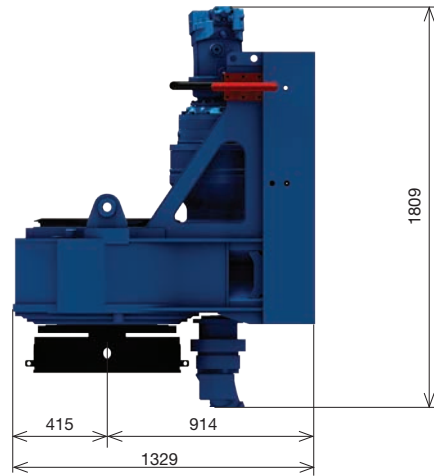
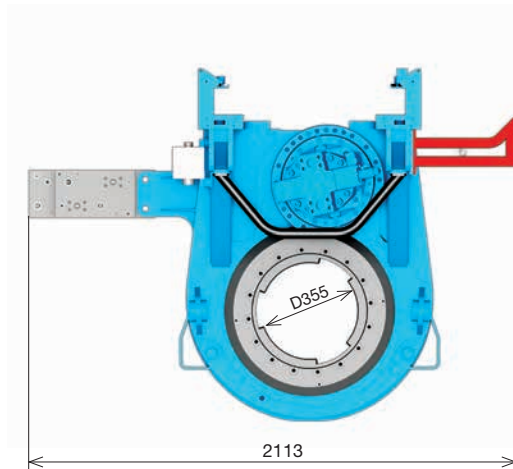

Rotary torque diagram

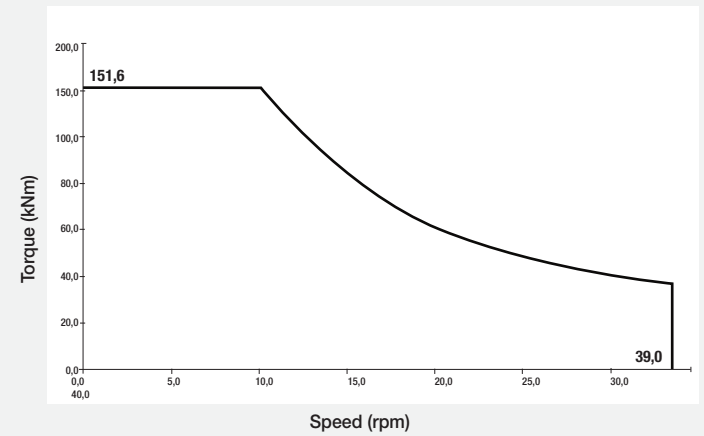

Kelly bars for rotary OD 355 mm/14 in.

Rotary motors displacement automatic controlled by DMS.

Rotary RD150 model	Displacement automatic control	Displacement automatic control
Max torque	151,6 kNm	111814 lb*ft
Rated torque	130 kNm	95883 lb*ft
Max drilling speed	39 rpm	39 rpm
Spin off speed	145 rpm	145 rpm
Weight (w/o cardan joint and casing flange)	2500 kg	5512 lb

CFA

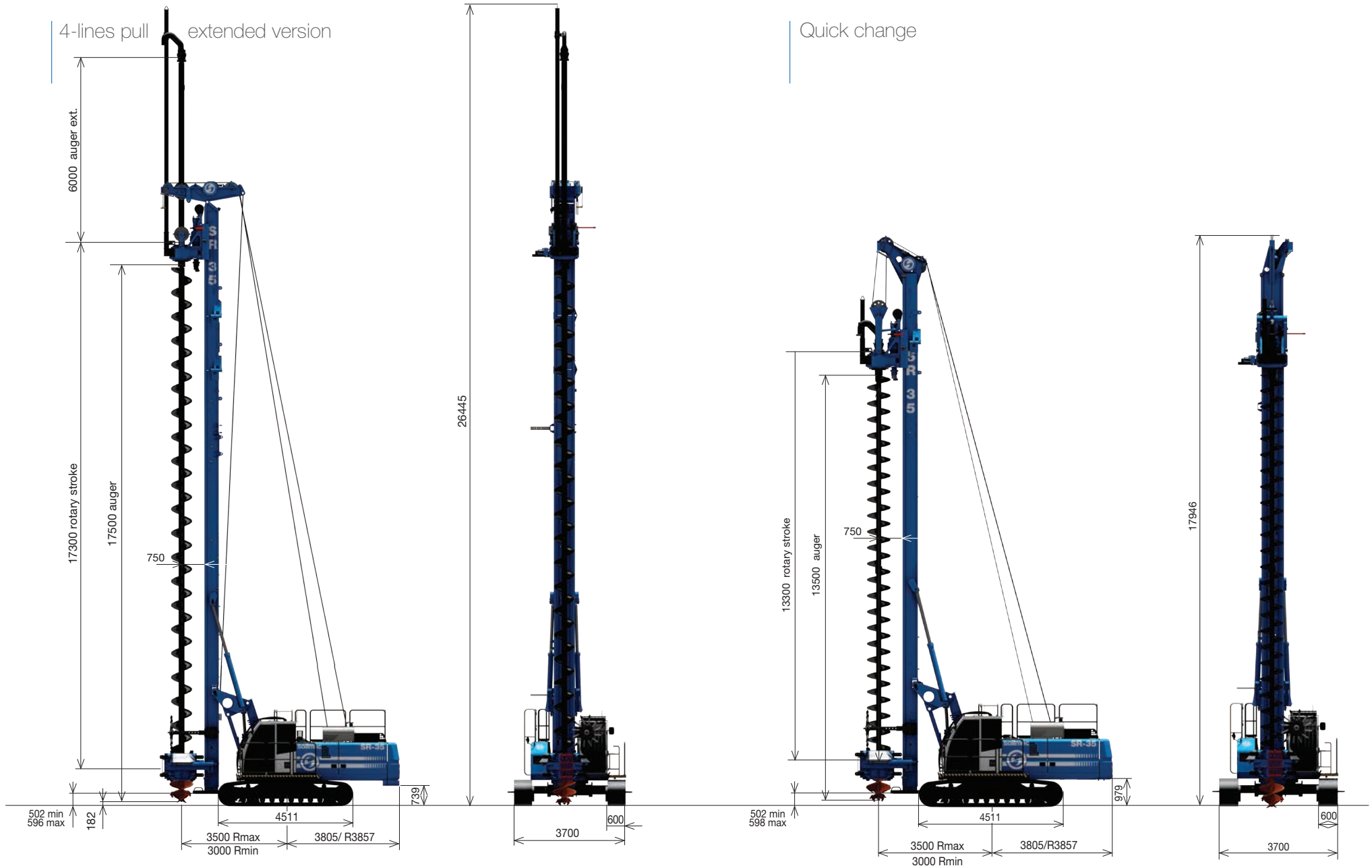

CFA - Continuous Flight Auger - 4 lines pull	standard version		extended version	
Operating weight (c/w 6 m / 19.6 ft sleeve extension, w/o auger) ¹	36400 kg	80248 lb	38600 kg	85098 lb
Max pile diameter	900 mm	35.43 in	900 mm	35.43 in
Max length of auger	13,5 m	44.29 ft	17,5 m	57.41 ft
Special sleeve extension length	8 m	26.25 ft	8 m	26.25 ft
Max pile depth c/w 6 m / 19.6 ft sleeve extension ²	19,0 m	62.34 ft	23 m	75.46 ft
Nominal extraction force	380 kN	85427 lbf	380 kN	85427 lbf
Additional crowd force on auger ³⁻⁴	100 kN	22481 lbf	100 kN	22481 lbf

CFA - Continuous Flight Auger - Quick change		
Operating weight (w/o sleeve extension, w/o auger) ¹	35000 kg	77161 lb
Max pile diameter	900 mm	35.43 in
Max length of auger	13,5 m	44.29 ft
Max length (w/o sleeve extension) ²	12,9 m	42.32 ft
Nominal extraction force	270 kN	60698 lbf
Additional crowd force on auger ³⁻⁴	100 kN	22481 lbf

¹with segmental mast option the weight is 500 kg (1102 lb) more
² depth reduced of 1,5 m (4.9 ft) with roller auger cleaner
³ package on request - depth reduced by 1,2 m (3.94 ft)
⁴ 37 kN (8318 lbf) also available on request - w/o depth reduction

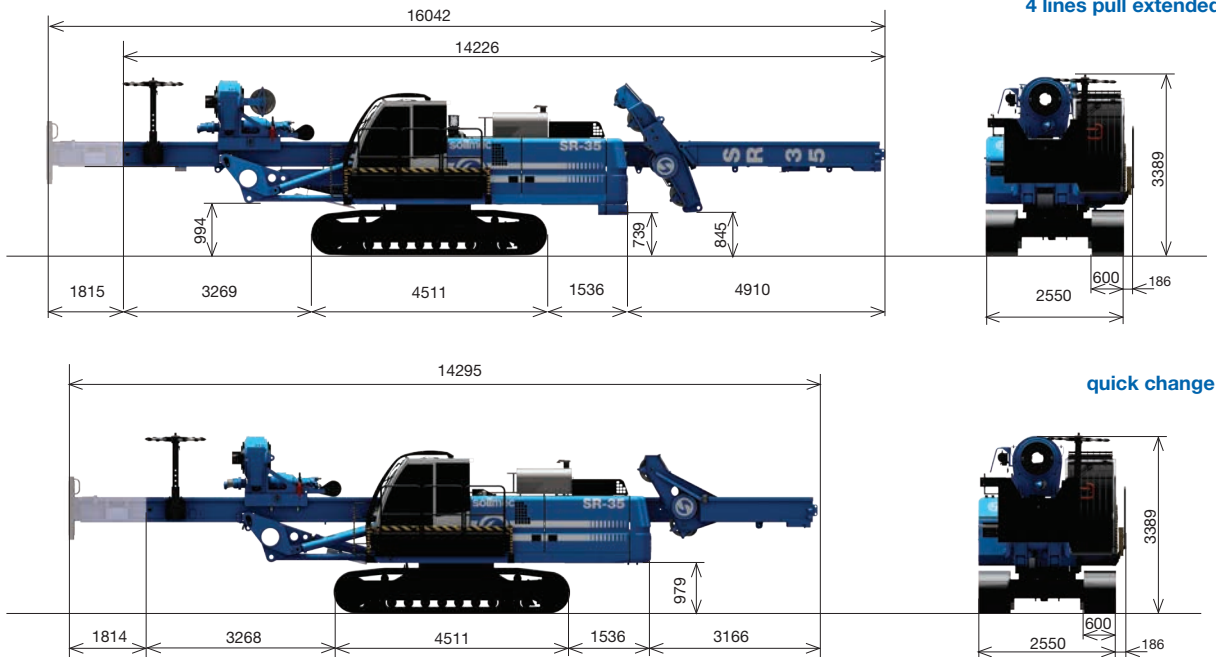

Transport in CFA - 4-lines pull	Standard		Extended		Quick Change	
Transport weight*	32600 kg	71871 lb	34800 kg	76721 lb	36100 kg	79587 lb
Transport length	14266 mm	46.8 ft	16042 mm	52.6 ft	37200 kg	82011 lb
Transport length w/o mast foot	12452 mm	40.9 ft	14226 mm	46.7 ft	12481 mm	40.9 ft
Transport width	2550/2736 mm	8.4/9.0 ft	2550/2736 mm	8.4/9.0 ft	2550/2736 mm	8.4/9.0 ft

* w/o mast foot 1500 kg (3307 lb); with segmental mast option the weight is 500 kg (1102 lb) more

Technical data

Undercarriage



Undercarriage		
Type	variable gauge, telescoping removable sides	variable gauge, telescoping removable sides
Overall width with retracted crawlers	2550 mm	100.39 in
Overall width with extended crawlers	3700 mm	145.67 in
Width of triple grouser track shoes	600 mm	23.62 in
Overall length of crawlers	4510 mm	177.56 in
Traction force	290 kN	65195 lbf
Travelling speed	2,2 km/h	1.4 mph

Winches

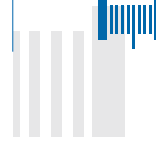

Main winch - standard		
Type	controlled descent	controlled descent
Model	SW135	SW135
Rope layers	2	2
Line pull (1st layer)	135 kN	30349 lbf
Rope diameter	22 mm	0.87 in
Rope speed (1st layer)	76 m/min	249 ft/min

Auxiliary winch		
Type	controlled descent	controlled descent
Rope layers	3	2
Line pull (1st layer)	65 kN	14612 lbf
Rope diameter	18 mm	0.71 in
Rope speed (1st layer)	67 m/min	220 ft/min

Engine



Engine		
Engine model	Cummins B 6.7	Cummins B 6.7
Power rating	179 kW @ 2200 rpm	240 HP @ 2200 rpm
Engine conforms to Exhaust emission Standard	EU stage V*	US EPA Tier 4*
Fuel tank capacity	350 l	92 US gal
AD Blue tank capacity	56,8 l	15 US gal

* Cummins QSB 6.7 - US EPA Tier3/EU stage III 183 kW (245 HP) available on request

Hydraulic system



Hydraulic system		
Main pumps flow	2x 176 l/min	2x 46 US gal/min
Third pump flow	97 l/min	26 US gal/min
Hydraulic oil tank capacity	380 l	100 US gal

Noise



Noise		
Sound pressure level in cab c/w stage V engine	110 dB	110 dB
Sound power level c/w stage V engine	75 dB	75 dB

Crowd system



CCS Cylinder Crowd System		
Stroke	3500 mm	137,80 in
Crowd force pull (down/up)	101,8/123,7 kN	22885/27809 lbf
Speed up (slow/fast)	19,4 m/min	64 ft/min
Speed down (slow/fast)	8,6 m/min	28 ft/min

Configurations

	LDP Large Diameter Pile with Kelly bar		CFA Continuous Flight Auger Piles	
	(CCS)	(LHR)	(4-lines pull)	(Quick change)
UNDERCARRIAGE				
Variable gauge, telescopic side frames	●	●	●	●
Machine anchor points for transport	●	●	●	●
Radio remote control for trimming operation	○	○	○	○
UPPER STRUCTURE				
Diesel engine B 6.7 EU Stage V – US EPA Tier 4F	●	●	●	●
Diesel engine Q5B 6.7 EU Stage IIIA – US EPA Tier 3	○	○	○	○
Start and slow system	●	●	●	●
Harness technology for electrical system	●	●	●	●
Automatic Greasing package	○	○	○	○
PTO kit for washing lance	○	○	○	○
1500 kg (3307 lb) additional counterweight	○	●	○	○
Catwalks for centre of turret	●	●	●	●
Rear ladder for turret access	●	●	●	●
Foldable side catwalks for cabin	○	○	○	○
Machine lifting kit (harbor use)	○	○	○	○
Upper handrails	●	●	●	●
Acoustic & light alarm for trimming	●	●	●	●
Lighting led system package	●	●	●	●
Sound proofed canopies	●	●	●	●
CAB				
Front protective grille	●	●	●	●
Falling object protective structure (FOPS)	●	●	●	●
Lower front protective grille	●	●	●	●
Rearview mirrors	●	●	●	●
Comfort package (cup holder, radio, A/C system, USB port and 12 V power socket, roll-up awning, courtesy lights)	●	●	●	●
Operator seat (air suspension, lumbar support, fully adjustable positioning, safety belt & operator presence micro-switch)	●	●	●	●
Front tools support	○	○	○	○
Service rope holder	●	●	●	●
Lighting system in front of the cab	●	●	●	●
CONTROL AND MONITORING SYSTEM				
DMS ON BOARD with technological package	●	●	●	●
DMS PC	●	●	●	●
DMS manager 4.0	○	○	○	○
GSM / GPRS / WIFI Modem	●	●	●	●
PLC processor for electrically actuated functions	●	●	●	●
DMS ON BOARD adjustable monitor 12" touch screen	●	●	●	●
Video control by 4 cameras with display in the cab	●	●	●	●
WINCHES				
Main winch SW135 model	●	●	●	●
Load cell for main winch	○	○	●	●
Limit switch for rope winding and winches	○	○	○	○
Depthmeter for main winch	●	●	●	●
Service winch SW65 model	●	●	●	●
Load cell for service winch	●	●	●	●
Anti-slack system for main winch	○	○	n.a	n.a

● standard ○ optional n.a. not available

	LDP Large Diameter Pile with Kelly bar		CFA Continuous Flight Auger Piles	
	(CCS)	(LHR)	(4-lines pull)	(Quick change)
ROTARY UNIT				
RD150 model Max torque intermitted: 151,6 kNm (111814 lbf)	●	●	●	●
Interchangeable rotary sleeve	●	●	●	●
Automatic greasing kit for cradle	○	○	○	○
Automatic control of motor displacement	●	●	●	●
MAST				
Segmental main mast	○	●	○	○
Mast guide cleaner	●	●	●	●
Kit for assisted rasing mast (patented)	○	○	○	○
Hydraulic foldable upper mast extension	○	○	○	○
Cathead with side service winch line	●	●	●	●
Cathead with folding jib on front	○	n.a	n.a	n.a
Cathead greasing kit	○	○	○	○
Double positioning of cylinder	n.a	○	n.a	n.a
1.1 m (43.3 in) mast extension	○	○	n.a	n.a
1.3 m (51.2 in) mast extension	n.a	○	n.a	n.a
KELLY BAR TECHNOLOGY				
Rotary sleeve with 3 ribs	●	●	n.a	n.a
Spin off discharging system	●	●	n.a	n.a
Cardan joint	●	●	n.a	n.a
Flange for casing driving ø 1300 mm (51 in)	●	●	n.a	n.a
Automatic return to the centre hole	○	○	n.a	n.a
Kelly bar guide	●	●	n.a	n.a
CFA TECHNOLOGY				
Hydraulic prearrangement for CFA 4th line pull	n.a	n.a	●	●
Sleeve HD-4 or HD-5, 3 m (118 in) long	n.a	n.a	○	n.a
Sleeve HD-4 or HD-5, 6 m (236 in) long	n.a	n.a	○	n.a
Sleeve HD-4 or HD-5, 8 m (315 in) long	n.a	n.a	○	n.a
Short sleeve	n.a	n.a	●	●
DMS ON BOARD with automatic auger lifting	n.a	n.a	●	●
Autodrilling package	n.a	n.a	○	○
Autorotary package	n.a	n.a	○	○
Additional pull-down winch 100 kN (22481 lb)	n.a	n.a	○	○
Openable lower guide ø 1200 mm (47 in)	n.a	n.a	●	●
Openable lower guide ø 750 mm (29.5 in)	n.a	n.a	○	○
Auger cleaner star type	n.a	n.a	○	○
Double roller auger cleaner ø 900 mm (35.4 in)	n.a	n.a	○	○
Two pressure transducers kit	n.a	n.a	○	○
WiFi pressure trasducer	n.a	n.a	○	○
Hydraulic prearrangement for VTH-1 vibrator	n.a	n.a	○	○
Automatic greasing package for CFA cathead	n.a	n.a	○	○
Drilling energy measurement kit for displacement/CFA	n.a	n.a	○	○
Automatic greasing kit for concrete swivel	n.a	n.a	○	○
13 m (42.7 ft) stroke kit	n.a	n.a	●	●
15 m (49.2 ft) stroke kit	n.a	n.a	○	n.a
17 m (55.8 ft) stroke kit	n.a	n.a	○	n.a



www.soilmec.it

This brochure has been edited and distributed by SOILMEC Spa. The present document cancels and overrides any previous ones. This brochure shall not be distributed, reproduced or exhibited without SOILMEC Spa. authorization in accordance with to SOILMEC web site disclaimer condition.

SOILMEC Spa distributes machinery and structures all over the world, supported by SOILMEC Spa subsidiary companies and dealers. The complete Soilmec network list is available on the web site www.soilmec.it